

**My comprehensive school: how I've enjoyed it so far:
a report for his Annual Review by an eleven year old boy
with Asperger syndrome
by Steven Rocco**

Address for correspondence

Glenys Jones, School of Education, Birmingham University, Edgbaston, Birmingham,
B15 2TT

Acknowledgements

We are very grateful to Steven and his family for giving their permission to publish this article and to the school SENCO, Lynne Duckett, for her assistance.

Editorial comment

This next article was written in June 1998 by an 11 year old boy with Asperger syndrome as his contribution to his Annual Review. It describes his first year at a mainstream comprehensive school. It is a lively account in which his enjoyment, engagement and enthusiasm for particular lessons shine through. The staff were particularly impressed by how much he had 'taken' from the lessons. His report was a piece of free writing and he was given no help from staff. Many parents and professionals have concerns about the ability of mainstream schools to address the specific needs of this group of children. This essay provides evidence of the potential benefits of such a placement directly from the child's perspective. Steven has just successfully completed Year 8 at the school. He has attended mainstream school throughout his education and currently receives 10 hours additional support each week. He is talented at drawing and loves music. Some of his drawings follow this account of his life at school.

How I've enjoyed it ^{so far}. By Steven Rocco

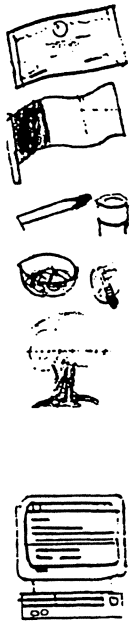

When I first came to the school, it was fab! Everything I did was great, I enjoyed all the lessons. The teachers were nice, Everything went exactly as I planned, I had thoughts like Every lesson would be like you were in a room with pupils listening to the teacher and working hard, The teacher at his desk, marking some work that had been done so far, It was amazing. My marks in R.E. were splendid, I had made friends with different people in my class, And in assembly I heard that people could earn merit certificates! Lots of Year 7 pupils earned

them, few people in my class had them. In Technology lessons, I did baking lessons, I had to mix and bake ingredients, it was really fantastic, I learned how to use the ovens, and how to make recipes. I moved on to sewing, I had fun whilst making a puppet, sewing and stitching, covering and tightening. I learned a lot in language. I learned how to say hello, and goodbye. The work was excellent. I liked science, all the flames and chemicals, but practical work sometimes makes me dizzy, I liked writing a lot, all the words and sentences make it look interesting. I enjoyed the trip to Bestwood park, we had a boat race and played other games we had lunch on the field. It was excellent. I had moved on, I had more work to do in the lessons, I learned a lot about computers in I.T. I had documents to look at, and I learned what a database is...



And I also learned how to draw on the computer. I like Music, all the instruments and words and good. I also practised some songs. And in history, it was very nice looking at all the ruins of buildings, and also viewing conflicts. Everything that happened in Roman times. And a few weeks later I had to do my Exam. But I did well answering questions and drawing plans. I may know what marks I got whilst finishing the exams. I did rather good. In Technology, I enjoyed C.D.T I made a money box and made a special circuit. A light lit when the coin went down the track. And when I moved on I did woodwork, it is brilliant, all the tools and other bits I used to cut wood worked well. I had pull the coping saw back to cut the wood out, and I used the planer to smoothen the wood, it was much better than glass paper, but when it came to smoothening the bottom of my wooden toy, it was tricky, the belt couldn't get the gap, so I had to use sand paper, I had to drill on wheels on my axle base to make sure it was level to roll.

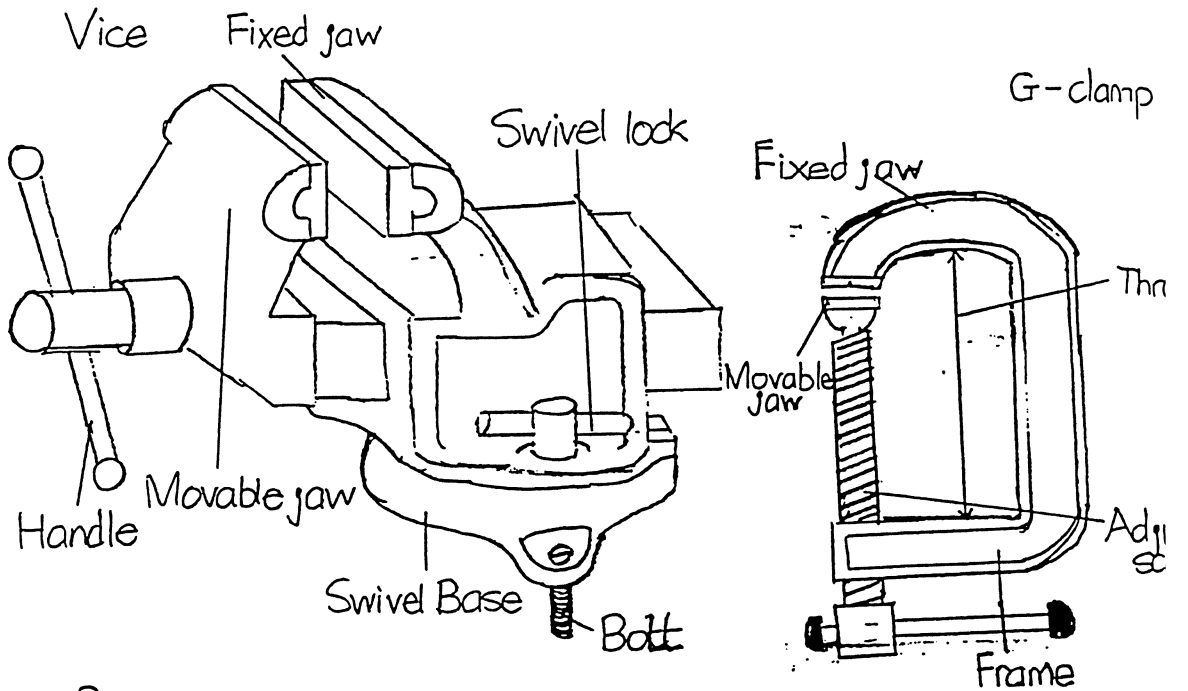
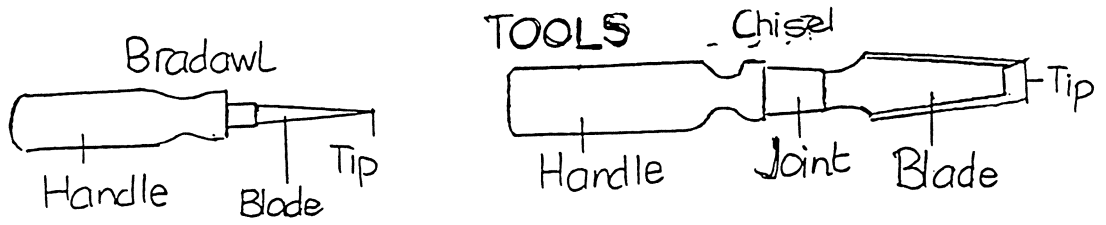

Brace

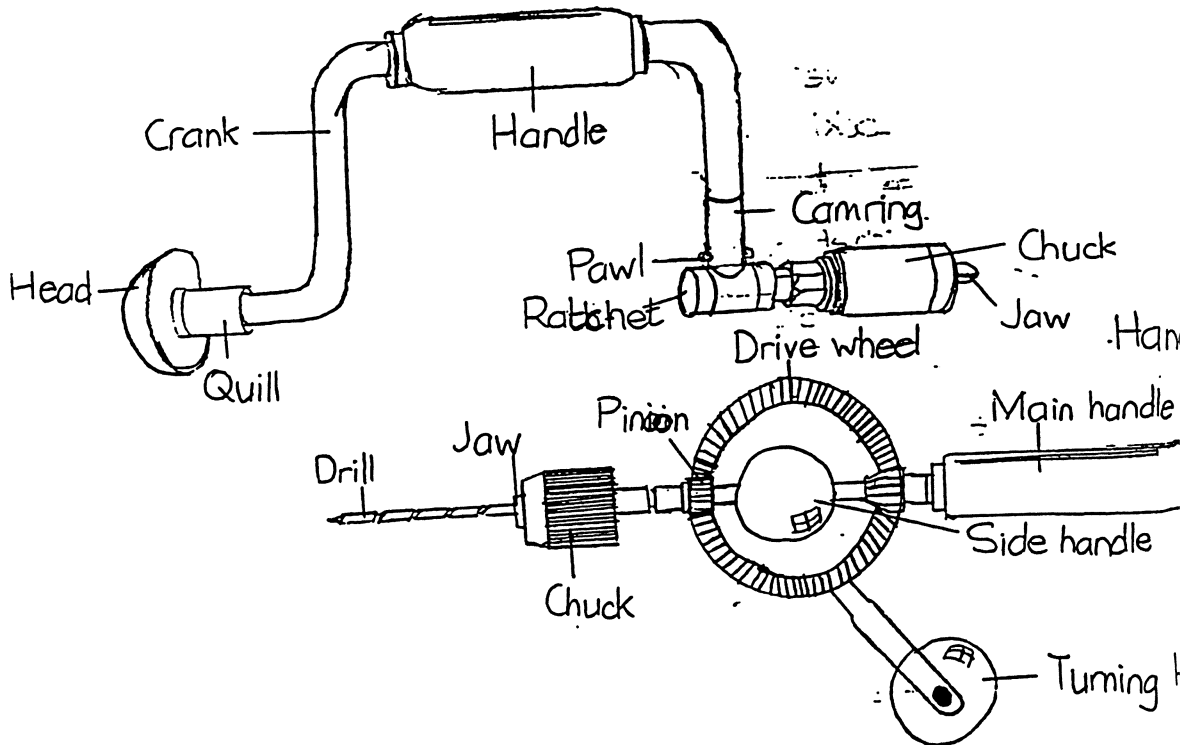

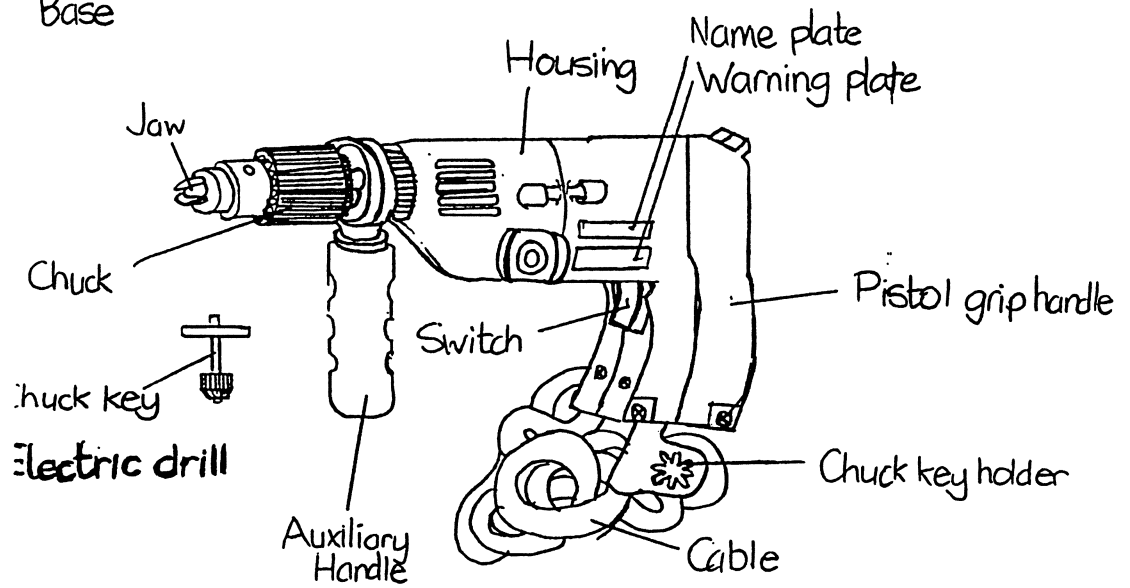
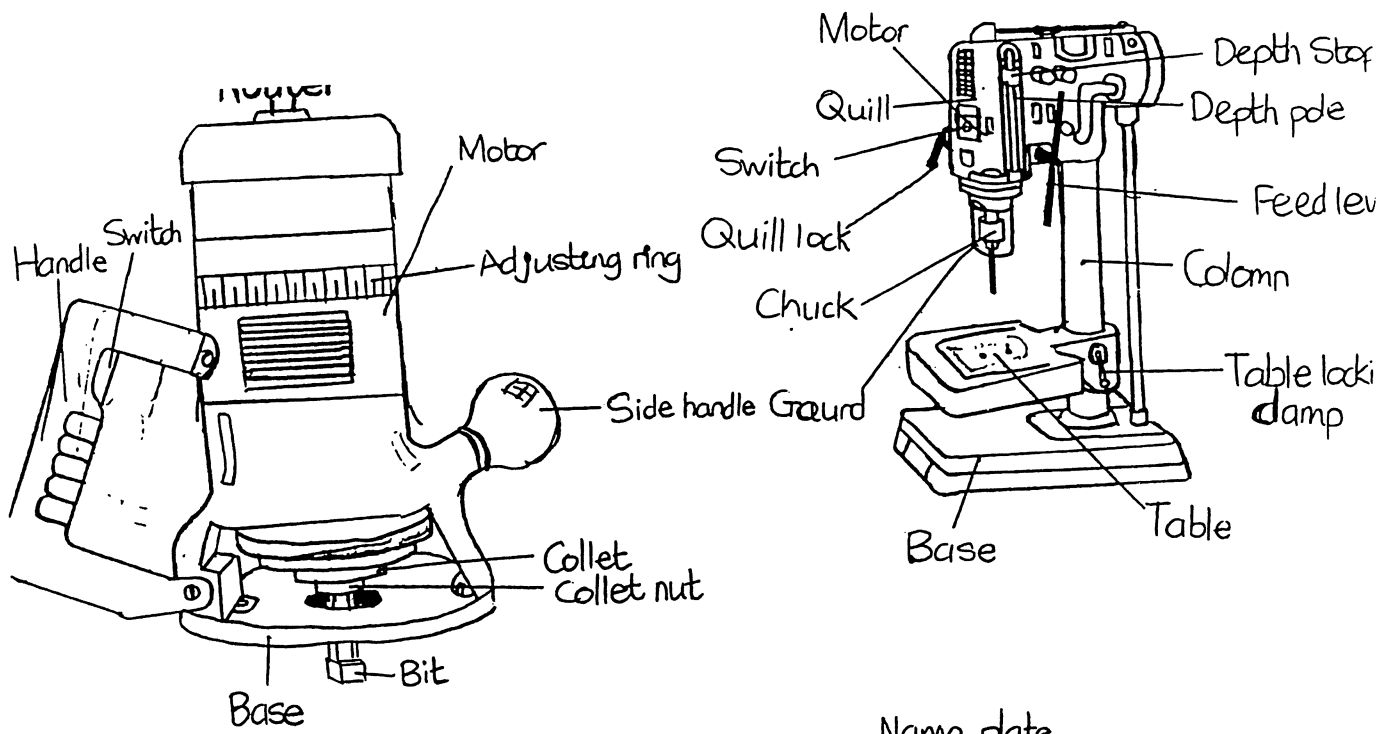

Linisher

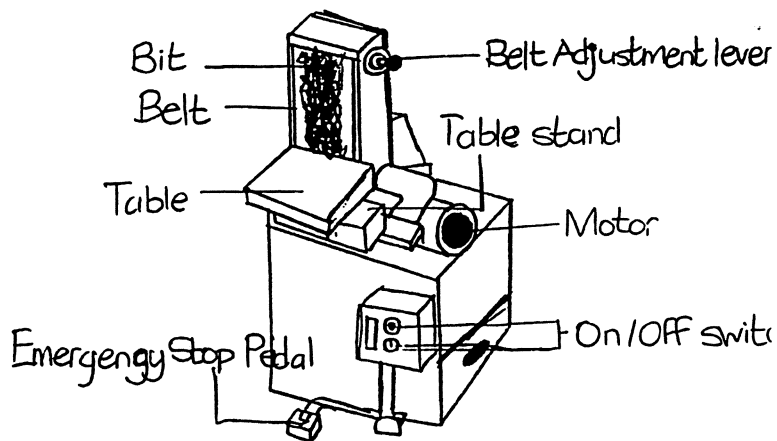

(Drawings produced by Steven)